

NOTE: 1
 DESIGN CODE:
 API 17H Type 1

NOTE: 2
 TECHNICAL CLASSIFICATION:
 Article Type: 001-Hot Stabs
 Main Group: 1.01. Ø35 Hot Stab
 Intermediate Group: 1.1.03. Protection
 Sub Group: 1.1.3.02. Dual

NOTE: 3
 INTERFACE INFORMATION:
 Pressure Rating Bar: N/A
 Material: PEHD 1000
 Weight: 0,1 kg
 Volume: 0,09 dm³
 Surface Area: 300 cm²
 Hydraulic: N/A
 Mechanical: N/A
 Electrical: N/A
 Com. & Protocol: N/A

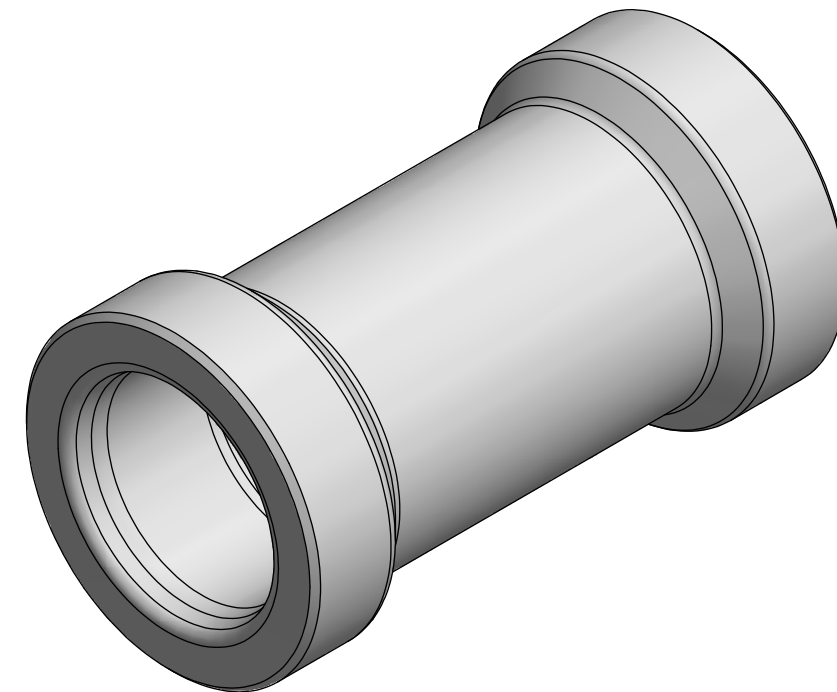
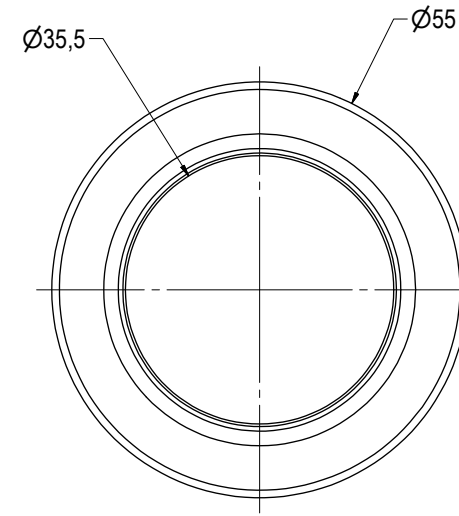
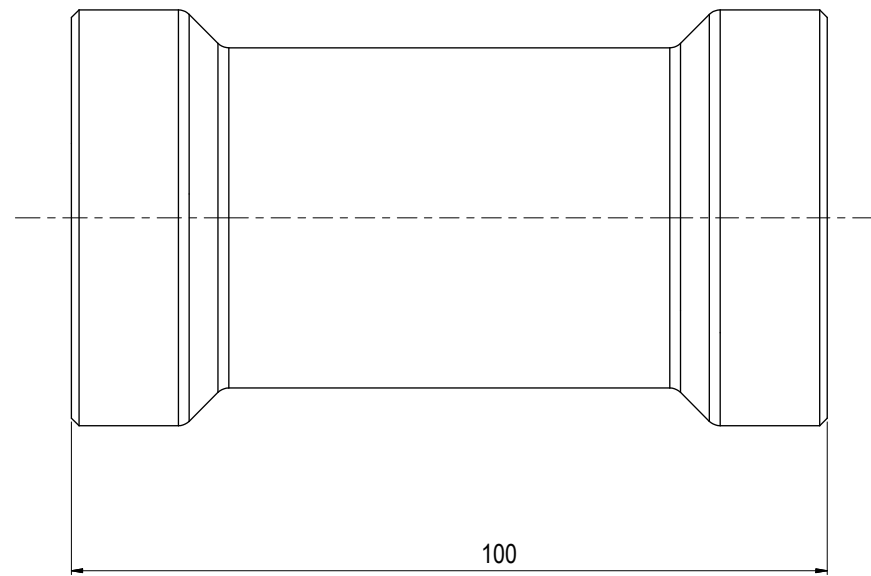

| Rev. | Date | Reason for issue | Revision change | Made | Chk'd | Appr. |
|------|-----------|---------------------------|-----------------|------|-------|-------|
| 02 | 11.2.2022 | 9-IFU (Issued for Use) | | HNJ | TAN | HNJ |
| 01 | 6.8.2021 | 2-IFT (Issued for Tender) | | HNJ | NA | NA |



| | | |
|--------------------------|---------------------------------------|--|
| Unless Noted Otherwise: | Dwg. Scale: NTS | Drawing title: Ø35 DP Stab Protection Sleeve |
| Dim. Tol: NS-ISO 2768-1 | Dwg. Proj: | |
| Roughness: Ra | Dwg. Format: A3 | |
| Fillet Rad: Corner Rmax: | Break Edges: (R. Alt. 45°) R= 0,1-0,5 | Drawing number: BB6844 |
| | | Rev. 02 |